

73

Mallas romboidales

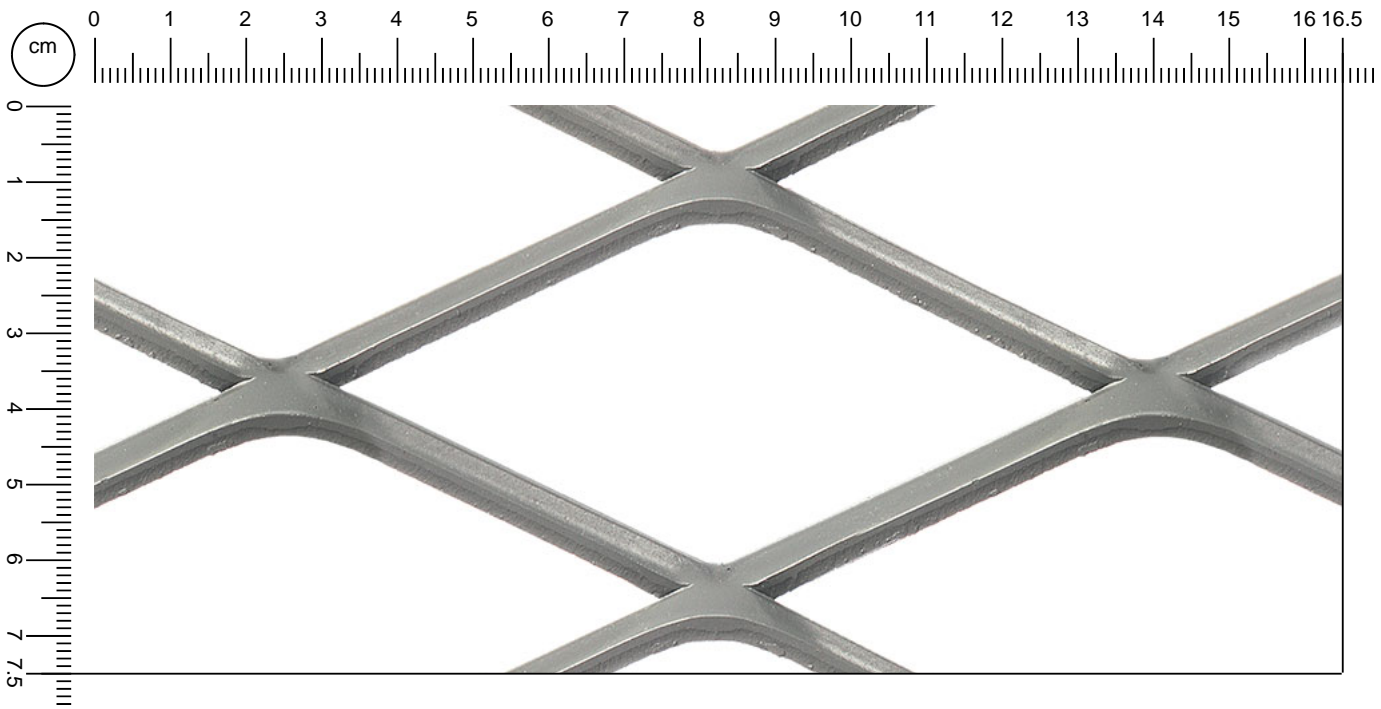

Product data:
R 115 x 55 (63) - 3 x e

Material	Name	sp mm	Peso kg/m2	Plancha Bajo demanda
Acero al carbono	R 115 x 55 (63) - 3 x 3	3,0	2,5	✔